



## **Ice Machine Parts List for Series S1400 Models**

**SD1402A**

**SY1404A**

**SD1403W**

**SY1405W**

**SD1492N**

**SY1494N**

**JC1395**

# S1400 CONTROL BOX

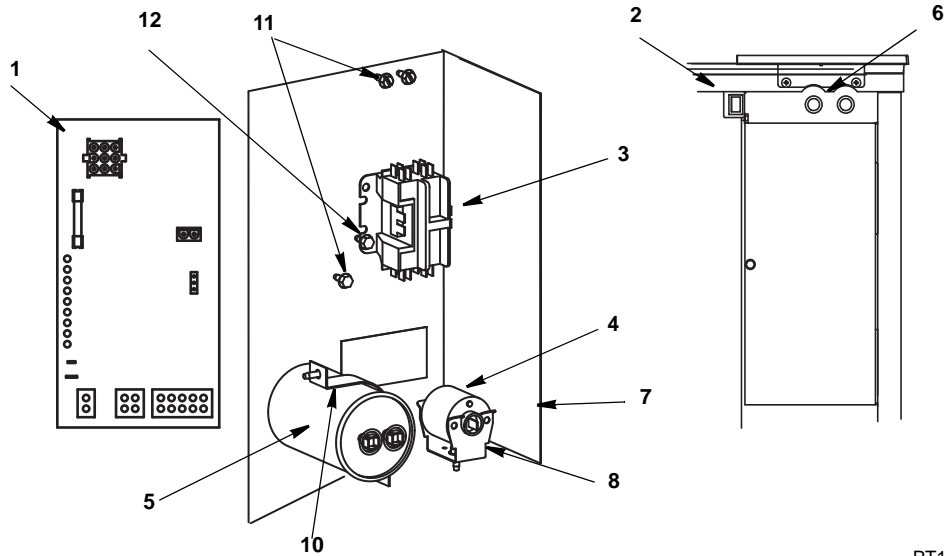

PT1388

## DESCRIPTION

	<b>PART NO.</b>
1 Control Board (for use with all voltages) . . . . .	20-0619-9
a. 7 Amp Fuse – Mounted on Control Board . . . . .	25-1100-3
2 <b>Toggle Switch</b> Only . . . . .	20-0793-9
a. Toggle Switch Wiring Harness . . . . .	20-0906-9
b. Toggle Switch Box . . . . .	40-1163-9
3 <b>Contactor</b>	
a. 208-230V/60 Hz/1 Ph or 230V/50 Hz 1Ph. . . . .	20-0908-9
b. 208-230V/60 Hz/3 Ph . . . . .	20-0661-9
4 P.T.C.R. Compressor Starter . . . . .	85-0491-3
5 Compressor Run Capacitor 208-230V/50/60 Hz/1 Ph). . . . .	20-1013-3
6 Refrigeration Service Valve Assembly . . . . .	83-7326-3

## Miscellaneous – Brackets, Screws, etc.

7 Control Box . . . . .	76-0214-3
a. Control Box Cover (Not shown) . . . . .	76-0315-3
b. Control Box Bracket . . . . .	606724-9
8 P.T.C.R. Compressor Starter Mounting Bracket . . . . .	85-0495-3
9 Control Board Mounting Supports (Not shown) . . . . .	43-0225-3
10 Capacitor Mounting Strap . . . . .	602495-1
11 Screw, #10-24 x .50 Ground . . . . .	52-0216-9
a. Star Washer . . . . .	55-7320-9
12 Screw, #10-24 x .50 . . . . .	52-0206-9
13 Control Box Wiring Harness (Not shown)	
a. 230/60/1. . . . .	20-0899-9
b. 230/60/3. . . . .	20-0897-9
c. 230/50/1. . . . .	20-0898-9
d. Harvest Air Assist Pump . . . . .	20-0900-9

# S1400 EVAPORATOR COMPARTMENT

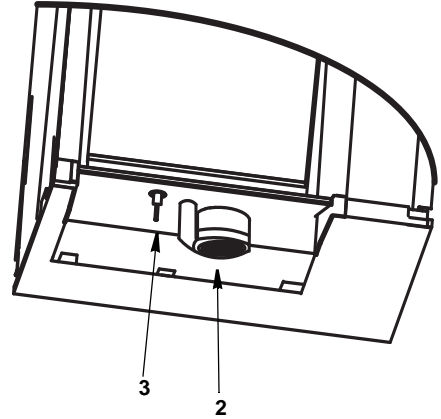
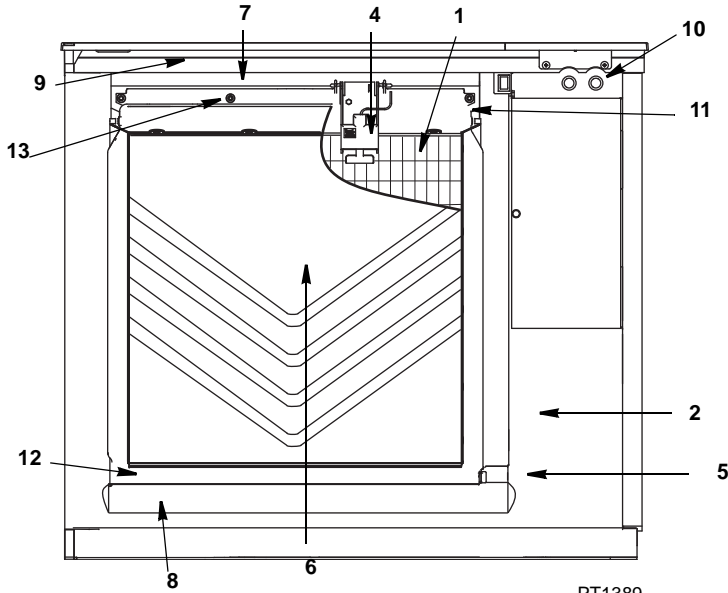

## DESCRIPTION

<b>1</b>	<b>Evaporator Assembly</b>	
	a. Dice Cube .....	76-0316-3
	b. Half Dice Cube .....	76-0317-3
<b>2</b>	<b>Water Pump</b>	
	a. 230V/50 Hz .....	20-0738-9
	b. 230V/60 Hz .....	82-5210-9
<b>3</b>	<b>Water Level Probe</b>	
	a. Wire, control box to probe .....	20-0654-9
<b>4</b>	<b>Ice Thickness Control Probe</b> .....	20-0916-9
<b>5</b>	<b>Magnetic Bin Switch</b> .....	20-0802-9
<b>6</b>	<b>Water Curtain</b> .....	20-0681-9
<b>7</b>	<b>Water Distribution Tube Assembly</b> .....	40-1423-9
	a. O-Rings (Back of Distribution Assembly) .....	76-0319-3
<b>8</b>	<b>Water Trough</b> .....	50-0464-9
<b>9</b>	<b>Evaporator Top Filler Panel</b> .....	40-0915-9
	a. Stainless Steel Clamp .....	30-0665-3
	b. Clamp Screw .....	606333-9
<b>10</b>	<b>Access Valve</b> .....	52-0209-9
<b>11</b>	<b>Evaporator Top Frame Assembly</b> .....	83-7326-3
<b>12</b>	<b>Water Diverter</b> .....	76-0320-3
		76-0318-3
<b>Miscellaneous – Brackets, Screws, etc.</b>		
<b>13</b>	<b>Screw, (Water Distribution Tube Mounting) Each</b> .....	50-0479-9
	a. O-Ring .....	50-0462-9
<b>14</b>	<b>Screw, #12-16 x .687 Used to Mount Evaporator (Each)</b> .....	50-0461-9
<b>15</b>	<b>Water Pump Base O-Ring</b> .....	50-0465-9
<b>16</b>	<b>Water Pump Outlet O-Ring</b> .....	50-0467-9
<b>17</b>	<b>Vinyl Tubing 0.625 ID (dump valve to drain adapter)</b> .....	000001382
	a. Insulation .....	603883-1

# S1400 REFRIGERATION COMPARTMENT – COMMON PARTS

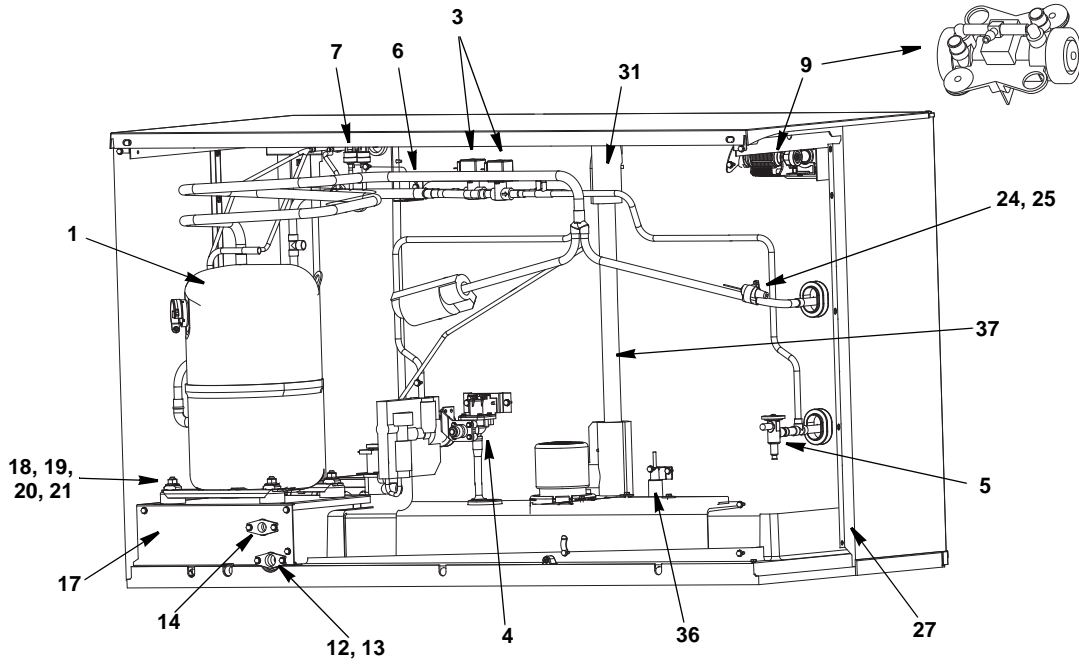

**DESCRIPTION**

**PART NO.**

<b>1 Compressor</b>	
a. 208-230V/60 Hz/1 Ph . . . . .	76-0321-3
a. 208-230V/60 Hz/3 Ph . . . . .	76-0322-3
b. 230V/50 Hz/1 Ph . . . . .	76-0323-3
<b>2 Water Dump Valve</b>	
a. Dump Valve, 208-230V/50-60 Hz . . . . .	000001768
b. Dump Valve Rebuild Kit. . . . .	No Longer Available
<b>3 Harvest Valve</b>	
a. Harvest Valve Including 208/230V 50/60 Hz Electrical Coil Danfoss . . . . .	76-3010-1
b. Harvest Valve 208/230V 50/60 Hz Coil Only Danfoss. . . . .	000002049
<b>4 Water Inlet Valve</b>	
a. Water Inlet Valve Including 208-240V/50-60 Hz Coil. . . . .	000000380
<b>5 Expansion Valve</b> . . . . .	76-0324-3
a. Expansion Valve Body Insulation Boot . . . . .	40-1329-9
b. Expansion Valve Bulb Insulation Boot . . . . .	40-0720-3
<b>6 Manifold Strainer (in front of hot gas valve)</b> . . . . .	82-5097-3
<b>7 High Pressure Cut-out (Auto Reset)</b> . . . . .	20-0124-3
<b>8 Electrical Box on Rear of Ice Machine</b>	
a. Box . . . . .	606728-9
b. Terminal Block 3 Pole . . . . .	20-0614-3
c. Groundscrew #10-24 x .50 . . . . .	52-0216-9
<b>9 Air Compressor</b>	
a. Air Compressor Pump 230V with bracket . . . . .	000000443
b. Manifold Tee (Air Pump Tubing Outlet) . . . . .	40-0457-9
<b>10 Compressor Compartment Wiring Harness</b>	
a. Water . . . . .	20-0901-9
b. Air . . . . .	20-0902-9
c. Remote . . . . .	20-0903-9

**Miscellaneous – Brackets, Screws, etc.**

11	Dump Valve Mounting Bracket . . . . .	605845-9
12	Water Inlet Valve Wing Adapter . . . . .	87-0608-3
13	Water Inlet Valve Wing Adapter Plastic Fitting . . . . .	13-6096-1
14	Water Drain Female Wing Adapter . . . . .	87-0609-3
15	Water Drain Clear Tubing, .625 ID x 12 inches . . . . .	44-2038-3
16	Dump Valve Tubing 3.25 inches. . . . .	44-2038-3
17	Compressor Mounting Base. . . . .	606590-9
18	Compressor Mounting Rubber Grommet. . . . .	85-0485-9
19	Compressor Mounting Sleeve . . . . .	85-0394-9
20	Compressor Mounting Bolt. . . . .	50-0481-9
21	Compressor Mounting Nut . . . . .	50-0482-9
22	Compressor Wiring Harness . . . . .	20-0623-9
23	Clamp, Water Drain . . . . .	56-5070-9
24	Clamp, Expansion Valve Bulb . . . . .	56-5052-9
25	Copper Bulb Strap . . . . .	30-0050-3
26	Screw, #10-24 x .50 . . . . .	52-0206-9
27	Left Corner Post . . . . .	606865-9
28	Left Top Channel . . . . .	606864-9
29	Right Corner Post. . . . .	606177-9
30	Right Top Channel . . . . .	606257-9
31	Overmolded Tube Assembly (vinyl tubing from distribution tube to water pump & dump valve) . . . . .	000000872
	a. Clamp .859/.989 ID. . . . .	56-5060-3
	b. Clamp .799/.899 ID. . . . .	56-5070-3
32	Water Inlet Valve Tubing . . . . .	40-1043-9
33	Connector Water Inlet Valve. . . . .	13-6098-9
34	Water Inlet Valve Bracket. . . . .	606644-9
35	<b>Check Valve Replacement</b> (includes water diverter, vinyl tubing & insulation) . . . . .	000002474
36	Holder, Water Level Probe . . . . .	20-0655-9
	a. Screw to Mount Water Level Probe Holder. . . . .	52-0206-9
37	Molded Vinyl Tube . . . . .	40-1426-9

## S1400 REFRIGERATION COMPARTMENT – AIR-COOLED

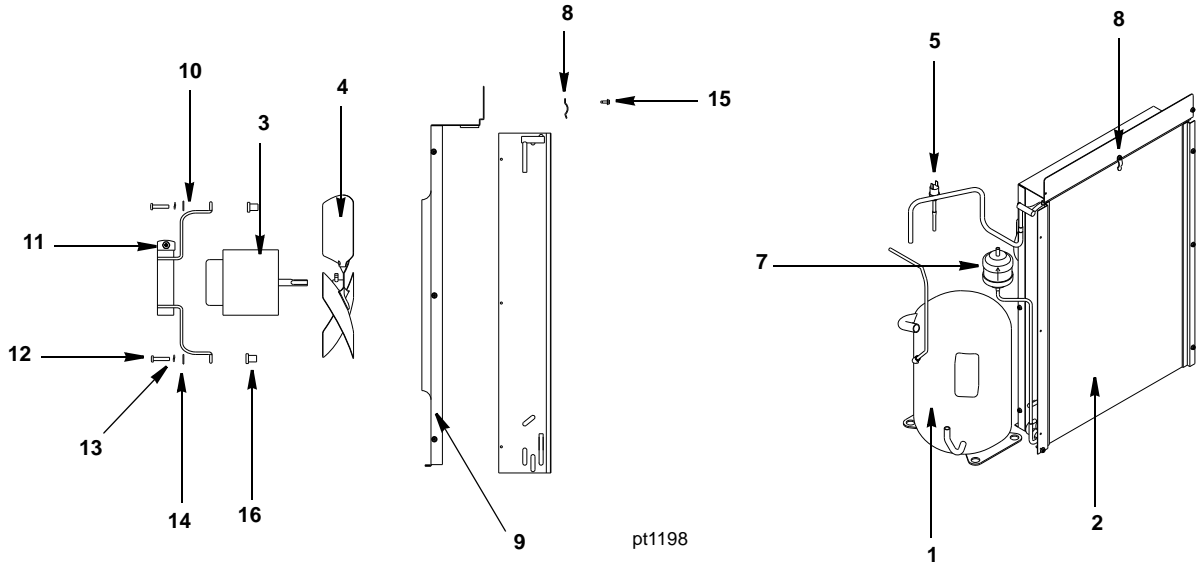

**DESCRIPTION**

	<b>PART NO.</b>
1 Compressor (Refer to COMMON PARTS Page) . . . . .	Page S1400-4
2 Air Condenser . . . . .	88-5128-3
3 Fan Motor (208-230V/60 Hz or 230V/50 Hz) . . . . .	76-2673-3
4 Fan Blade . . . . .	24-1611-3
5 Fan Cycling Control . . . . .	† 20-0127-3
6 Air Filter (Not shown) . . . . .	40-4024-3
7 Drier . . . . .	89-3027-9

**Miscellaneous – Brackets, Screws, etc.**

8 Air Filter Clip . . . . .	† 56-5069-9
9 Fan Shroud . . . . .	606849-9
10 Fan Motor Mounting Bracket . . . . .	30-0682-3
11 Fan Motor Mounting Screw . . . . .	† 50-3358-9
a. Fan Motor Mounting Lockwasher . . . . .	† 55-4510-9
b. Fan Motor Mounting Hexnut . . . . .	† 54-2952-9
12 Fan Bracket Mounting Screw . . . . .	50-3238-9
13 Fan Bracket Mounting Lockwasher . . . . .	† 55-4510-9
14 Fan Bracket Mounting Flatwasher . . . . .	† 55-7305-9
15 Screw, #10-24 x .50 . . . . .	† 52-0206-9
16 Wellnut . . . . .	54-2955-9

† Refer to Cross Reference Guide

# S1400 REFRIGERATION COMPARTMENT – WATER-COOLED

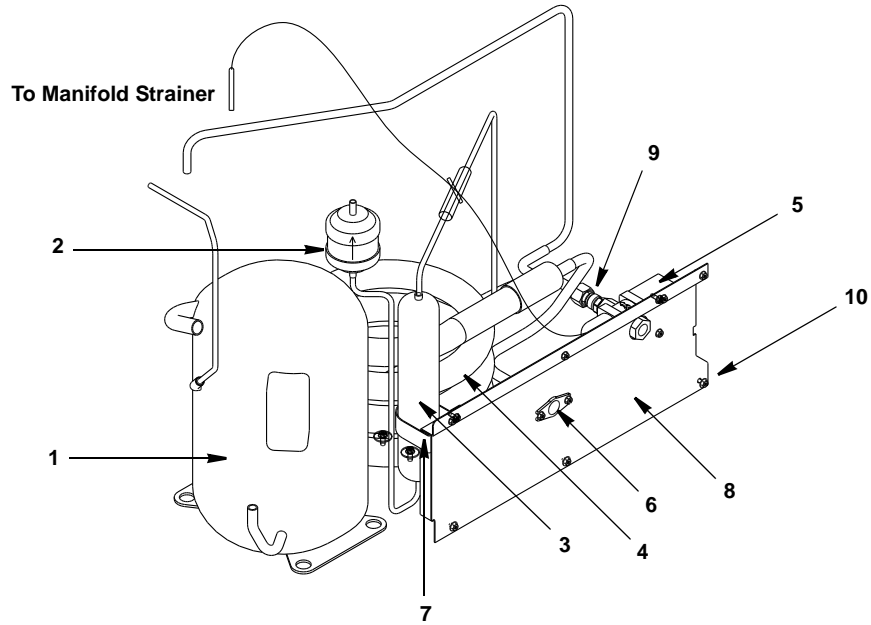

pt1200

## DESCRIPTION

	<b>PART NO.</b>
1 Compressor (Refer to COMMON PARTS Page) . . . . .	Page S1400-4
2 Drier . . . . .	89-3027-9
3 Receiver . . . . .	89-0035-3
4 Water-Cooled Condenser . . . . .	000001508
5 Water Regulating Valve . . . . .	83-7212-3
6 Water Drain Female Wing Adapter . . . . .	87-0608-3

## Miscellaneous – Brackets, Screws, etc.

7 Receiver Strap . . . . .	600054-1
8 Back Panel . . . . .	606682-9
9 Elbow .50 MF x .50 NPT . . . . .	50-0545-3
10 Screw, #10-24 x .50 . . . . .	52-0206-3
11 Washer . . . . .	55-7341-9
12 Base, Water Condenser/Receiver . . . . .	606684-1

# S1400 REFRIGERATION COMPARTMENT – REMOTE

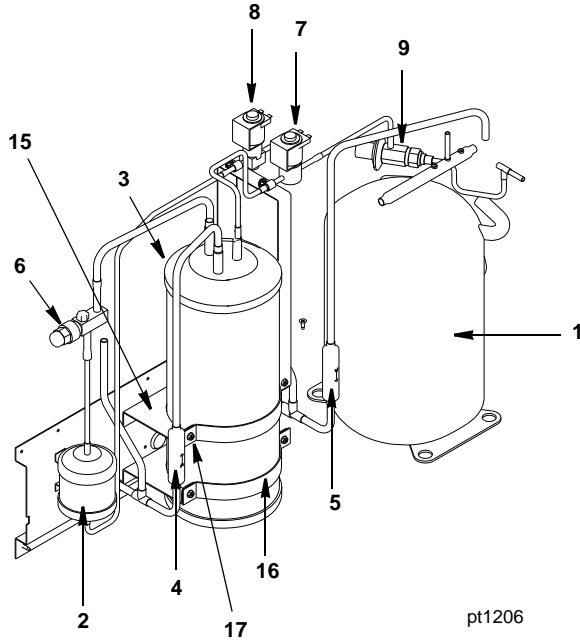

pt1206

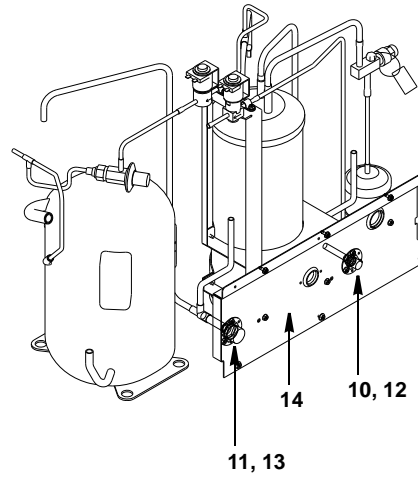

pt1207

## DESCRIPTION

	<b>PART NO.</b>
1 Compressor (Refer to COMMON PARTS) . . . . .	Page S1400-4
2 Drier . . . . .	89-3027-9
3 Receiver . . . . .	89-0001-9
4 Magni-Check Valve 3/8" . . . . .	83-7314-9
5 Magni-Check Valve 1/2" . . . . .	83-7315-3
6 Refrigeration Service Valve . . . . .	† 83-7316-9
a. Cap for Refrigeration Service Valve . . . . .	56-5075-9
7 <b>Harvest Pressure Regulating Solenoid (HPR) Valve</b>	
a. HPR Valve Including 208/230V 50/60 Hz Electrical Coil (Danfoss). . . . .	76-3006-1
b. HPR Valve 208/230V 50/60 Hz Coil Only Danfoss . . . . .	000002049
8 <b>Liquid Line Solenoid (LLS) Valve</b>	
a. LLS Valve Including 208/230V 50/60 Hz Electrical Coil (Danfoss) . . . . .	76-3009-1
b. LLS Valve 208/230V 50/60 Hz Coil Only Danfoss. . . . .	000002049
9 Harvest Pressure Regulating Valve (HPR) . . . . .	† 83-6779-3
10 Coupling – Male, 5/8-18 . . . . .	† 83-6034-3
11 Coupling – Male, 1-1/6-12 . . . . .	† 83-6035-3
<b>Miscellaneous – Brackets, Screws, etc.</b>	
12 Coupling Mounting Flange for 5/8-18 . . . . .	83-6005-3
13 Coupling Mounting Flange for 1-1/16-12 . . . . .	83-6006-3
14 Back Panel . . . . .	606682-9
15 Receiver Mounting Bracket. . . . .	600056-1
16 Receiver Mounting Strap . . . . .	630721-4
17 Screw, #10-24 x .50 . . . . .	† 52-0206-9

† Refer to Cross Reference Guide



## S1400 PANELS

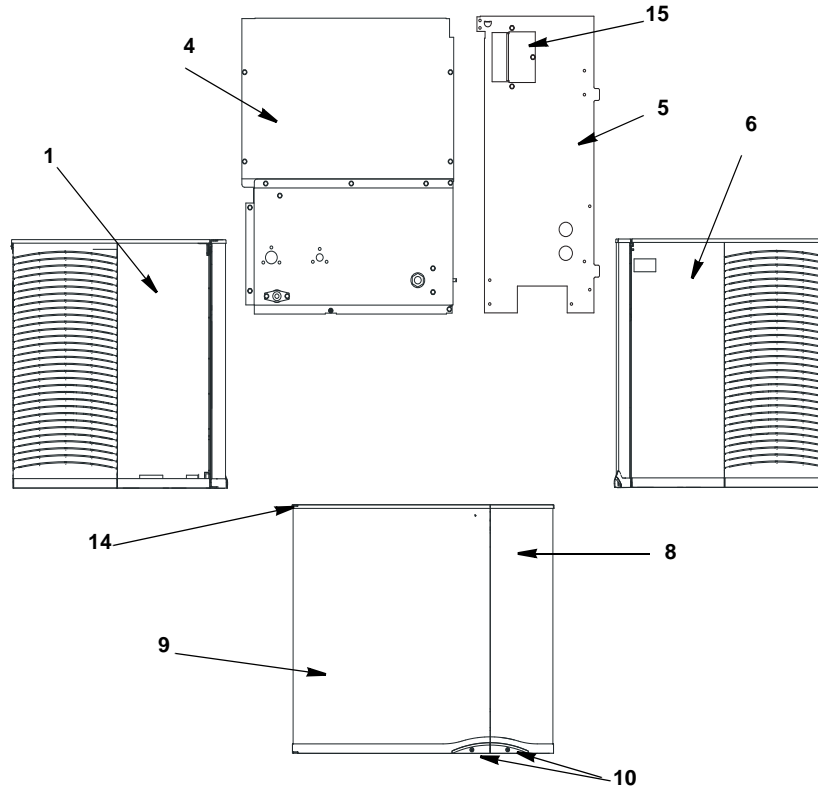

### DESCRIPTION

DESCRIPTION	PART NO.
1 Left Side Panel . . . . .	606055-9
2 Air Baffle . . . . .	605971-9
3 Air Filter (Not shown) . . . . .	40-4024-3
4 Back Panel, Remote or Water . . . . .	606970-9
5 Back Panel, Air . . . . .	606973-9
6 Right Side Panel . . . . .	606054-9
7 Top Cover (Not shown) . . . . .	40-1203-9
8 Right Door . . . . .	606868-9
9 Left Door . . . . .	606867-9

### Miscellaneous – Brackets, Screws, etc.

10 Right/Left Door Screw . . . . .	50-0489-9
11 Front Top Support (Not shown) . . . . .	30-0574-9
a. Mounting Screw Left Side 8-32 x 1 . . . . .	50-0537-9
b. Mounting Screw Right Side 10-24 x .50 . . . . .	50-0509-9
c. Front Panel Strike . . . . .	30-0602-9
12 Bottom Door Frame . . . . .	40-1188-9
a. Mounting Screw Left Side 8-32 x 1 PHIL . . . . .	50-0537-9
b. Mounting Screw Right Side 10/24 x .50 PHIL . . . . .	52-0209-9
13 Door Catch Bracket (RHD) . . . . .	606236-9
a. Mounting Screw 8-32 x .50 Phil . . . . .	50-2624-9
14 Left Door Pivot Leaf Hinge (Top or Bottom) . . . . .	30-0557-9
a. Mounting Screw 8-32 x 1 PHIL . . . . .	50-0537-9
15 Electrical Connection Box Cover . . . . .	606729-9
16 Top Cover Bracket . . . . .	606404-9
17 Sachet Holder (inside left door) . . . . .	40-0459-9
a. Screws . . . . .	50-0479-9

## JC1395 REMOTE CONDENSER (USED WITH S1400 REMOTE ICE MACHINES)

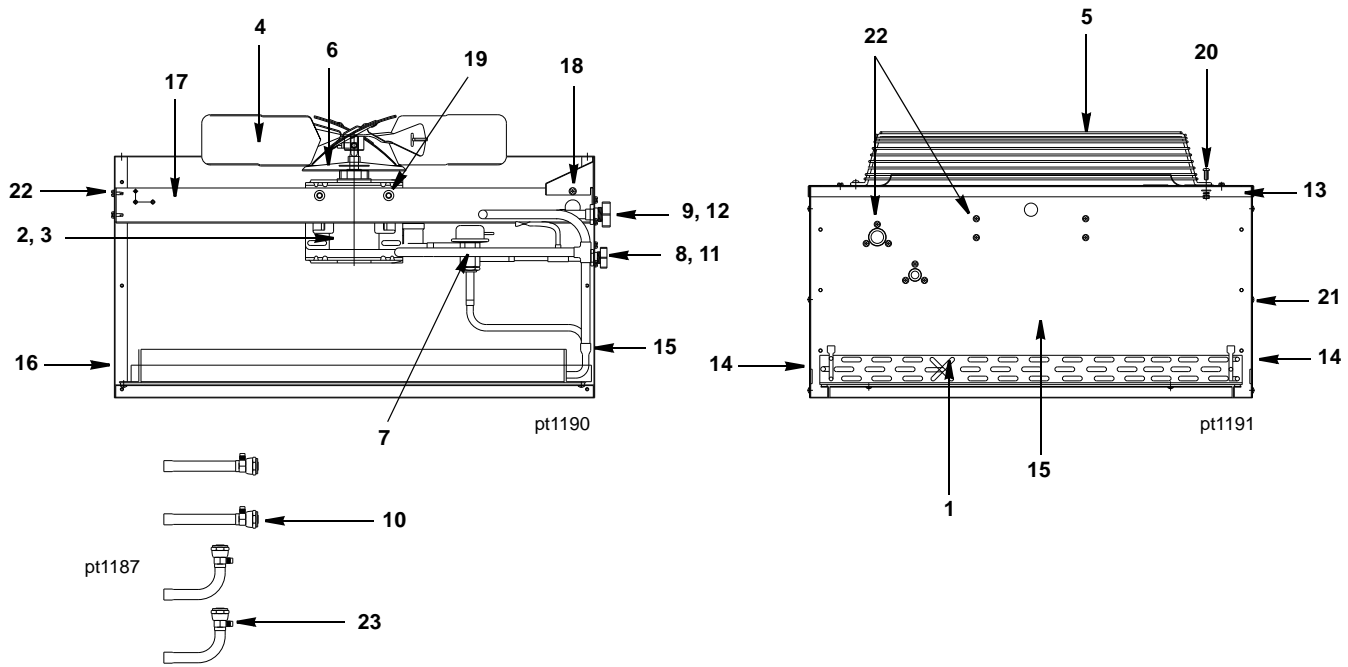

### DESCRIPTION

DESCRIPTION	PART NO.
1 Air Condenser . . . . .	88-5090-3
2 Fan Motor (208-230V 50/60 Hz/1 Ph). . . . .	† 76-2941-3
3 Fan Motor Run Capacitor (Emerson) . . . . .	85-0458-3
3 Fan Motor Run Capacitor (Magnatec) . . . . .	No Longer Available
4 Fan Blade . . . . .	24-1611-3
5 Fan Guard. . . . .	34-0064-3
6 Rain Slinger . . . . .	24-1505-3
7 Head Pressure Control . . . . .	83-6809-3
8 Coupling – Male, 5/8-18 . . . . .	† 83-6034-3
9 Coupling – Male, 1-1/6-12 . . . . .	† 83-6035-3
10 Female Line Set Coupling Kit (Sold as Finished Goods Sales Kit) . . . . .	Sales K0129

### Miscellaneous – Brackets, Screws, etc.

11 Coupling Mounting Flange (for 5/8-18) . . . . .	83-6005-3
12 Coupling Mounting Flange (for 1-1/16-12) . . . . .	83-6006-3
13 Top Cover . . . . .	601789-1
14 Panel – Side . . . . .	† 601790-1
15 Panel – Rear . . . . .	601791-1
16 Panel – Front . . . . .	† 601792-1
17 Fan Motor Mounting Bracket . . . . .	† 601768-1
18 Electrical Box Cover . . . . .	† 601776-1
19 Fan Motor Mounting Screw (5/16-18 x 5/8) . . . . .	† 50-3565-9
a. Fan Motor Mounting Flatwasher . . . . .	† 55-7309-9
b. Fan Motor Mounting Lockwasher . . . . .	† 55-7313-9
c. Fan Motor Mounting Hexnut . . . . .	54-2975-9
20 Fan Guard Mounting Screw (1/4-20 x 5/8) . . . . .	† 50-3345-9
a. Fan Guard Mounting Flatwasher . . . . .	† 55-7304-9
b. Fan Guard Mounting Lockwasher . . . . .	† 55-4511-9
c. Fan Guard Mounting Hexnut . . . . .	† 54-2952-9
21 Panel/Condenser Mounting Screw (#8 x 1/2) . . . . .	† 51-2153-9
a. Panel/Condenser Mounting Lockwasher . . . . .	† 55-4459-9
22 Screw (#10-24 x .62) . . . . .	† 52-0205-9
23 Valve Cores (used in linesets) . . . . .	76-2684-3
24 Legs (Not shown) . . . . .	† 601769-1

† Refer to Cross Reference Guide